



**STOVE USED FOR LOCAL HEATING
ALFA TERM -27**



INSTALLATION, SETUP AND OPERATION INSTRUCTIONS

0. TECHNICAL DATA

HEATING CAPACITY WITH THE GRATE IN DOWN POSITION:	
---	--

Nominal heating capacity (wood/coal)	27,56 kW / 26,7 kW
Heating capacity by radiation of heat (wood/coal)	7,44 kW / 6,4 kW
Heating capacity to water (wood/coal)	20,12 kW / 20,3 kW
HEATING CAPACITY WITH THE GRATE IN UP POSITION:	
Nominal heating capacity (wood/coal)	20 kW / 20 kW
Heating capacity by radiation of heat (wood/coal)	6 kW / 6kW
Heating capacity to water (wood/coal)	14 kW/14 kW
REQUIRED CHIMNEY DRAFT	20 Pa
FLUE PIPE CONNECTION DIAMETER	150 mm
HEIGHT FROM THE FLOOR TO FLUE PIPE CONNECTION AXIS	690 mm
STOVE DIMENSIONS:	
Width	900 mm
Height	850 mm
Depth	600 mm
OVEN DIMENSIONS:	
Width	330 mm
Height	260 mm
Depth	440 mm
FIREBOX DIMENSIONS:	
Width	315 mm
Height (min/max)	264/460 mm
Depth	414 mm
FIREBOX DOOR OPENING (width/height)	175/200 mm
FLOW AND RETURN PIPE CONNECTIONS	R1" RS
THERMO VALVE AND SAFETY VALVE CONNECTIONS	R1/2" RU
COOLING PIPE CONNECTIONS	R1/2" RS
BOILER VOLUME	25 l
HEATING VOLUME WITH THE GRATE IN DOWN POSITION:	
Heating volume by radiation of heat	90 – 115 m ³
Hot water (radiator) heating volume	250 – 335 m ³
HEATING VOLUME WITH THE GRATE IN UP POSITION:	
Heating volume by radiation of heat	75 – 100 m ³
Hot water (radiator) heating volume	175 – 230 m ³
MAXIMUM OPERATING PRESSURE	1,9 bar
MAXIMUM OPERATING TEMPERATURE	90 °C
WEIGHT (gross/net)	219/195 kg
FLUE GAS TEMPERATURE (wood/coal)	207 / 229 °C
CONTENT OF CO (13% O ₂)	0,55 / 0,93 %
ENERGY EFFICIENCY	76,92 / 74,4 %

Heating capacity is given for dry beech wood used as firewood, with lower calorific value of Hd = 4255 W/kg, and brown coal Hd = 4926 W/kg.

DEAR CUSTOMERS!

Thank you for placing your trust in us and purchasing our stove used for local heating.

We assure you that you have chosen a cost-effective, quality product, which is the result of our extensive experience in manufacturing stoves and furnaces that are used for local heating.

We hope that we fully met your demands in both design and the size of the living area you need to heat.

Before installing up this stove, please carefully read these instructions and observe all advice provided therein.

1. PURPOSE

Solid fuel stove for local heating is used for:

- cooking,
- baking,
- heating of apartments, houses and office premises,
- domestic hot water production.

It is most often used as a stove for local heating, however, it can also be installed for central heating.

This stove is intended for household use and may not be used for commercial purposes.

2. APPEARANCE AND STRUCTURE OF STOVE WITH BOILER FOR HEATING (Fig. 1)

- | | |
|--|--|
| 1. Stove cover | 16. Pressure gauge |
| 2. Cooktop (hotplate) | 17. Thermometer |
| 3. Cooktop extension | 18. Cooktop lid |
| 4. Damper open and close knob | 19. Thermostat (combustion regulator) damper |
| 5. Oven door | 20. Smoke pipe connection |
| 6. Oven thermometer | 21. Cleaning access plate |
| 7. Firebox door | 22. Handle |
| 8. Secondary air regulator knob | 23. Grate support |
| 9. Ash pan door | 24. Additional lid |
| 10. Thermostat (combustion regulator) knob | 25. Lever support |
| 12. Ash pan (ash box) | 26. Tertiary air regulator knob |
| 13. Grate holder | 27. Tertiary air regulator cover |
| 14. Wood box | 28. Cleaning access plate – smaller |
| 15. Cleaning access plate | 30. Tertiary air regulator |

3. SAFETY AND RELIABILITY OF STOVE OPERATION

The stove used for local heating is designed to ensure maximum operational safety.

Stove operational safety is ensured by the following three elements:

- combustion regulator (thermostat) (Fig. 1, Item 10), located in the ash pan door, which automatically shuts the air supply into the firebox when the preset water temperature in the boiler is reached,
- Thermal valve (thermal fuse) (Fig. 7, Item 13 and Fig. 7a) when installed in the heating system serves as a thermal fuse if the stove becomes overheated,
- safety valve (Fig. 7 and 8, Item 5) which MUST be installed on an R1/2" connection (Fig. 4, Item 4.)
- **NOTE:**
- **Thermal valve and safety valve are not delivered with stove, while the thermostat is installed on the stove's ash pan door.**

4. INSTALLING THE STOVE

- The stove can be installed in the kitchen or at any other appropriate place.
- The substrate under the stove should be noncombustible.
- In the event of a combustible substrate (wood, plastics), place a metal sheet plate which should extend the sides of the stove by 10 cm and the front side by 50 cm.
- Furniture and objects adjacent to or in the vicinity of the stove should not be made of combustible materials. However, if they are made of combustible materials, minimum clearance to the stove should be 20 cm.

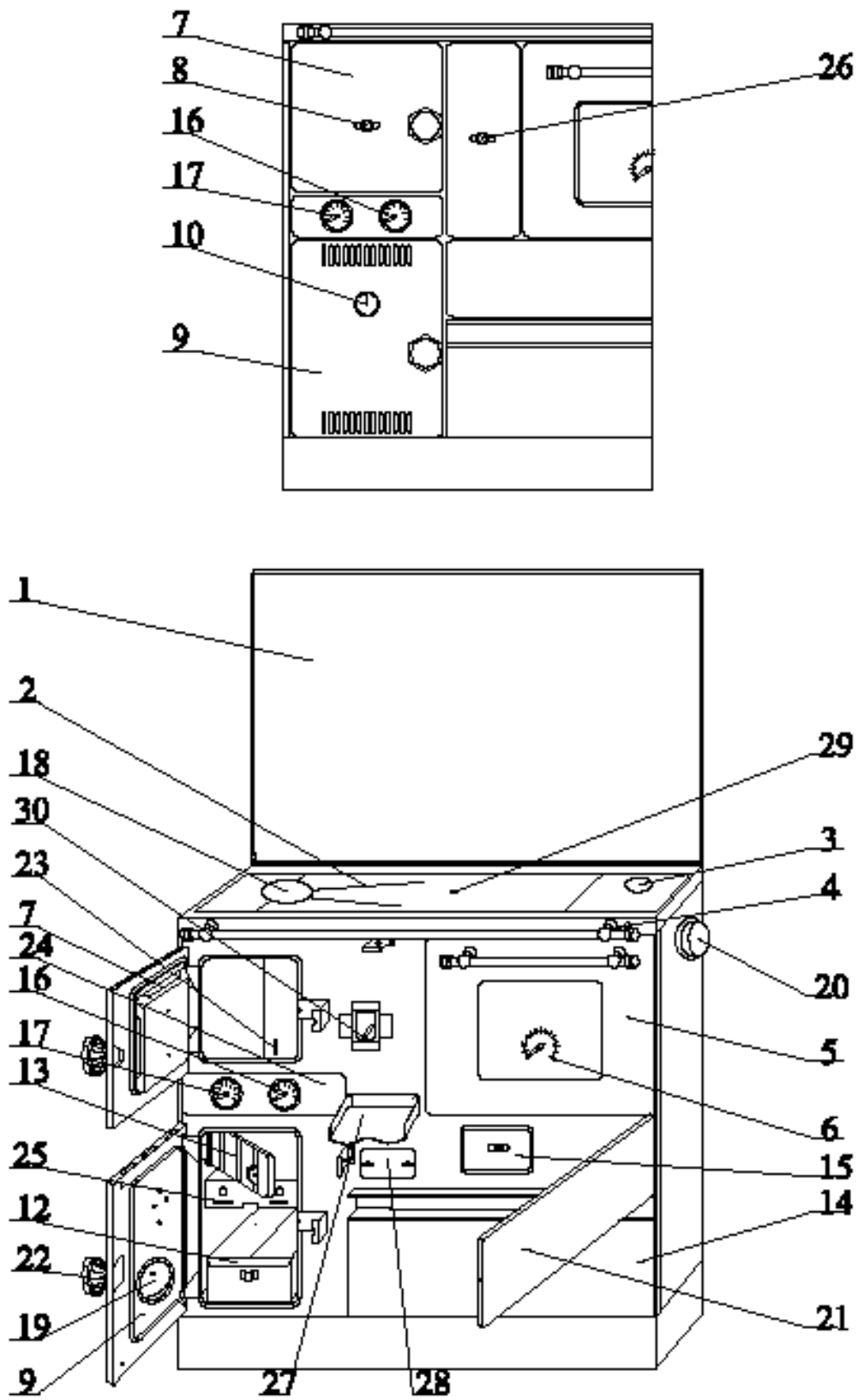

Figure 1

- If a cabinet is mounted above the stove, minimum clearance between the stove's cooktop and the cabinet should be at least 70 cm.
- Combustible materials (e.g. wallpapers, door casings, doors, etc.) require a clearance to flue pipes of at least 20 cm. This clearance can be reduced if flue pipes are thermally insulated and if the temperature of surrounding objects does not exceed 80°C.
- The stove should be placed in a horizontal position or with its back slightly raised (3-4 mm).

5. CONNECTING TO CHIMNEY

Inspect the unpacked stove and study the stove parts and accessories, and in particular, make sure that:

- asbestos-free sealing wires, which ensure tight sealing and prevent uncontrolled entry of air, are fitted in special ducts of the firebox door, ash pan, cleaning access plate and cooktop frame,
- combustion regulator (thermostat) correctly opens and closes the thermostat damper (Fig. 1, Item 19), by using the regulation knob (Fig. 1, Item 10),
- grate holder (Fig. 1, Item 13) is properly fitted on its supports and that it is easily opened.

Place the chimney connection (collar), which is delivered together with the stove and placed inside the wood box, and screw it on the outlet on the cooktop or on the side outlet. First remove the cover and use the same screws to fasten the collar.

NOTE:

If your chimney is of unsatisfactory or dubious quality, we recommend that you attach the collar on the cooktop outlet and not on the side outlet.

The stove will reach its nominal heating capacity if the draft in the chimney is 20 Pa. A chimney ensuring good draft is the basis of proper functioning of the stove. The chimney not only affects the stove's output, but also the combustion quality. Chimney draft directly depends on the chimney's cross-section, height, internal wall roughness and the difference between the temperature of gas and external air. We recommend the following chimney sizes that ensure good draft:

Stove type	Nominal heating capacity (kW)		Chimney height (m)				
			5	6	7	8	9
ALFA TERM 27	brown coal	wood	Clear opening dimensions (mm)				
	26,7	27,56	Ø200	145x200	Ø160 145x145	Ø160 145x145	Ø160 145x145

- Having a properly operating chimney and observing other requirements with respect to the material specified below, ensures flawless stove operation.
- If chimney draft exceeds 20 Pa, install a damper inside the flue pipe.
- Chimney connection should be vertically positioned.
- Horizontal pieces of flue pipes over 0.5 m long should slope upwards by 10° toward the chimney.
- Flue pipe connection, flue pipes and chimney may not taper.
- All joints, including the chimney, must be well sealed and there must be no soot or dirt inside the flue pipes.
- Protect the chimney from the cold (thermally insulate the chimney). This specially refers to chimneys made of metal sheets or chimneys built on exterior walls.
- Flue pipes that are not thermally insulated and that are placed in a vertical position may not be over 1.25 m long.

Draft intensity is checked using a candle (Fig. 2).

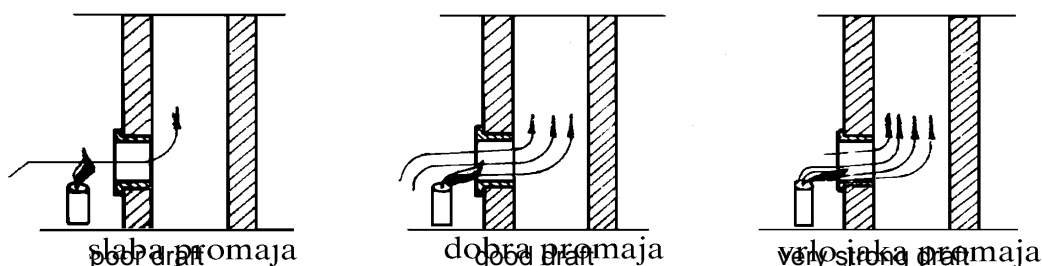
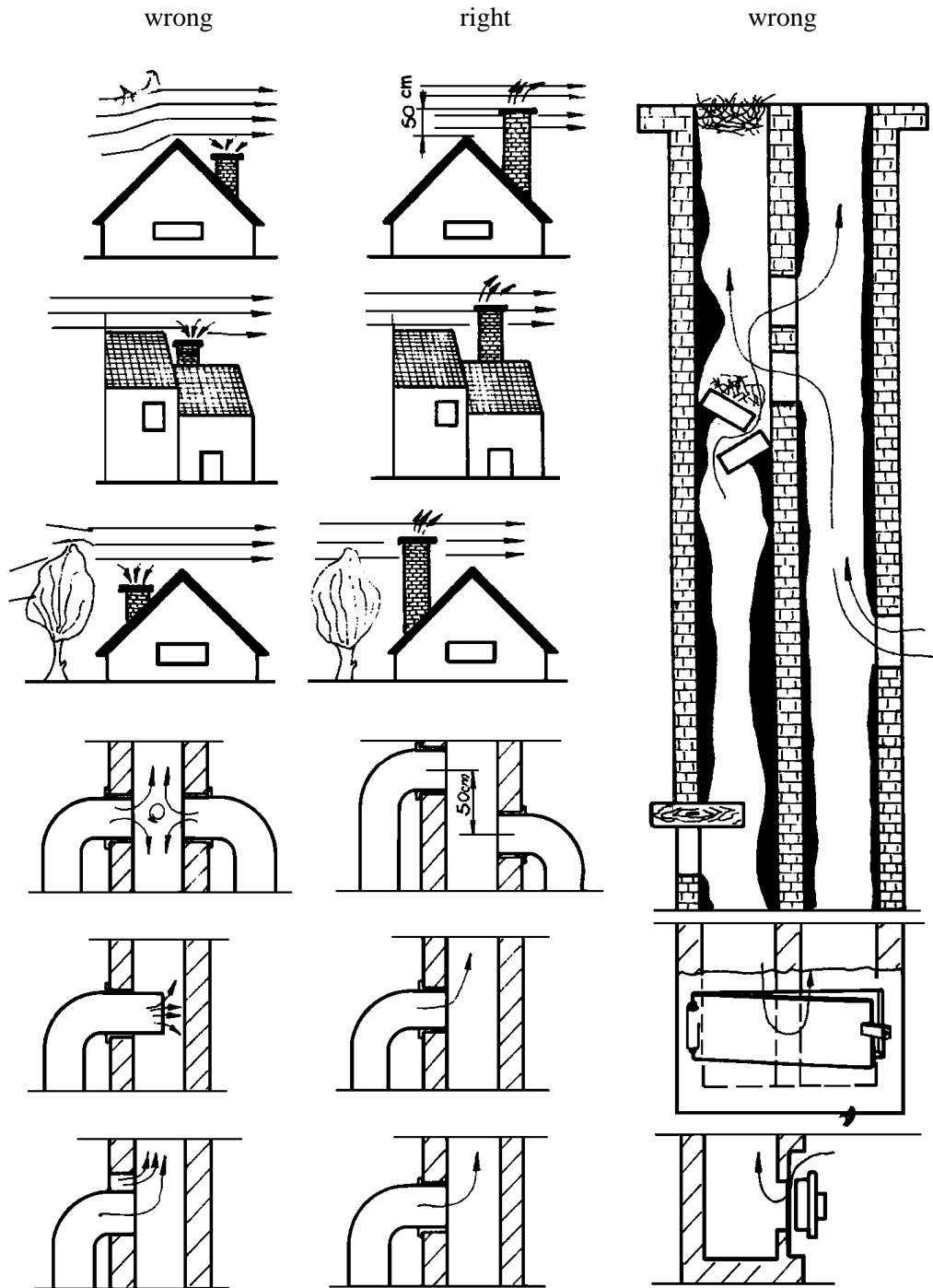

Figure 2

A chimney is properly functioning, if it meets the following conditions (Fig. 3):

- If it extends the height of the rooftop (ridge, highest point) by at least 0.5 m,
- If it extends the height of the house adjacent to the chimney, tree or other barrier,
- If it is built inside house walls or, if the chimney is built on the outside walls, it must be well insulated,
- If the chimney connection is tightly connected to the chimney, if the connection is extended,
- If it is properly cleaned and free of birds nests, dirt and soot,
- If the flue pipe does not enter deeply inside chimney opening, since this reduces the space for the smoke to exit,
- If all other required openings and cleaning access plates are well shut (sealed) to prevent generation of "false" air,
- If its duct is independent from other installation and has no cap on top.



6. INSTALLING THE STOVE IN THE WATER HEATING SYSTEM

The stove should be installed by a professional, in accordance with appropriate design. The stove is intended for local and central heating.

The stove can be installed in closed or open heating circuit. Conform to the standards: JUS M.E7.201 and JUS M.E7.202. Closed and open circuit diagrams are shown on Fig. 7 and Fig. 8.

The back of the boiler and connections are shown in Fig. 4 where:

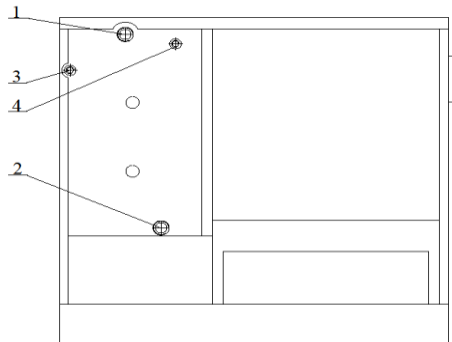

Figure 1

- Item 1 is an R1" connection with an outer thread for the flow pipe,
- Item 2 is an R 1" connection with an outer thread for the return pipe,
- Item 3 is an R1/2" connection with an inner thread for installation of the thermal valve safety pipe,
- Item 4 is an R1/2" connection with an inner thread for safety valve installation.

6.1 FLOW PIPE AND RETURN PIPE (Fig. 4, Items 1 and 2 and Fig. 7 and 8, Items 3 and 10)

The size of the flow pipe and return pipe outlets is 1" and may not be reduced or tapered before the first branch. Use 1" steel pipe or copper pipe of outer diameter Ø 28 mm (or larger diameter).

While installing the system, absolutely make sure that pipe slopes are 0.5% (5 mm of pipe length) and that the air is released from the system (from the boiler, pipes, radiators).

You can install a combination temperature and pressure gauge on the flow pipe, although both thermometer and pressure gauge are installed at the front of the stove.

On the return pipe, install a by-pass line with a pump, expansion vessel and a spigot for filling up and emptying the system. When you install the pump, take note of the pump's direction.

Note:

Only install the by-pass line if there are conditions for gravity heating.

6.2 THERMAL VALVE WITH BUILT-IN THERMAL PROTECTION AND ADDITIONAL ELEMENTS FOR CONNECTION

To install thermal valve it is necessary to purchase and install:

1. Thermal valve with built-in thermal protection type 544, 1/2", product Caleffi (Fig. 7a) and Fig. 7, Item 13.
2. Slope pressure regulator with manometer 1/2", the same or similar as shown in Fig. 7b and Fig. 7, Item 19.
3. Filter for cold water at the input of the water supply to the thermal valve, Fig. 7, Item 20
4. Filter for hot - boiling water intake of the boiler and water outlet of thermal valve, Fig. 7, Item 21.

Note:

These components are not included with product for central heating you bought!

Installation of thermal valve with built-in thermal protection (Fig. 7, Item 13 and Fig. 7a) with additional elements ensuring safe operation, such as pressure regulator (Fig. 7, Item 19 and Fig. 7b). Water filter on the boiler intake (Fig. 7, item 20) and water filter on the boiler outlet in closed central heating system is **MANDATORY**. This specially refers to a closed system, when the radiators are submerged and where in case of termination of the pump operation for any reason, the water temperature in the boiler rapidly increases and overheating occurs very quickly.

In the open central heating system, installation of thermal fuse is not mandatory.

6.2.1 THERMAL VALVE WITH BUILT-IN THERMAL PROTECTION (Fig. 7, Item 13 and Fig. 7a)

Thermal fuse is installed near the stove, depending on the available space. It can be installed in any position. You should take into account the direction of cold water intake and hot water outlet from the boiler which is clearly marked on the valve body.

The thermal fuse probe (Fig. 7, Item 22) is best to place in the thermal valve connection (Fig. 7, Item 18). It can be placed on the discharge - distribution pipe (Fig. 7, Item 3) but at a distance from the boiler of 500 mm the most or at the highest point of the boiler before the exhaust pipes.

Seal it with hemp or other sealing material by tightening.

Fig. 7 shows the thermal valve installation diagram.

The device is of one piece with the thermal valve and valve for filling.

Valve opening temperature is 100°C (+0°C/-5°C).

The fluid recommended in the installation is water and glucose antifreeze of 30%.

Note:

At reaction, and valve operation, during fluid cooling in an overheated boiler part of the new fluid is injected into the boiler, but the part is also ejected from the boiler. It will be poured down the drain. If the antifreeze is in the installation you must keep in mind that a certain percentage will go out and pour down the drain!

We recommend the thermal valve Caleffi type 544, 1/2" as shown in Figure 7a.

6.2.2 SLOPE PRESSURE REGULATOR 1/2" WITH MANOMETER (Fig. 7, Item 19 and Fig. 7b)

When installing the thermal valve it is required to mount the slope pressure regulator as shown in Fig. 7, Item 19. The pressure that is maintained by pressure regulator must be set at a higher pressure than the pressure that is in the heating system. If you do not have a higher water pressure of at least 0.8 bar compared to the pressure in the heating system thermal valve will not work or cannot inject cold water into the boiler that needs to be cooled.

Pressure regulator should be set to 2.8 to 3 bars.

You should take into account the direction of placing the slope pressure regulator!

6.2.3 WATER FILTER OF THE BOILER INTAKE (Fig. 7, Item 20)

In front of the slope pressure regulator on water intake from water supply line it is necessary to install a filter that will clean the water from solid objects, primarily of sand, which can damage the tap seal or seals of the thermal valve and the slope pressure regulator.

This filter does not need to be resistant to high water temperatures due to cold water that flows through.

6.2.4 WATER FILTER OF THE BOILER OUTLET (Fig. 7, Item 21)

It is required to install the filter on the boiler outlet which will clean the hot - boiling water from dirt and solid objects that can damage the tap seals, or seals of the thermal valve.

This filter must be resistant to water temperatures up to 150°C.

NOTES:

- After the completion of thermal valve activation, checking the pressure in the installation and filling the system with cold water is mandatory.
- In cases where antifreeze is used, after filling the installation with water it is required to check percentage content of antifreeze in a mixture of water and antifreeze!
- To avoid elimination of the antifreeze agent solution from the installation, it is best to have backup battery supply of the pump with an inverter.

6.3 SAFETY VALVE (Fig. 7 and 8, Item 5 and Fig. 4, Item 6)

An R1/2" connection (Fig. 4, Item 6) is welded at the back of the boiler, under the cooktop frame, on which a safety valve MUST be fitted. The safety valve should be 2.5 to 3 bars. You can fit it directly on the connection or at a distance from the connection of at least 1 m, provided that there is no block valve between the boiler and the safety valve.

In general, safety valve is not fitted in open circuits, but we advise you to fit it nonetheless, as another safety precaution for the boiler and the system (in case of emergency).

NOTE:

If the safety valve is not fitted as described above, the warranty will not be valid.

6.4 THERMOMETER AND PRESSURE GAUGE (Fig. 1, Items 16 and 17 and Fig. 5)

Thermometer and pressure gauge are installed on the stove, on the additional lid (Fig. 1, Item 24) between the firebox door and the ash pan door (Fig. 1, Items 16 and 17, and Fig. 5) and therefore it is not necessary to install them.

Thermometer, Item 17, shows the temperature of water in the boiler (operating temperature) in °C.

Pressure gauge, Item 16, shows the pressure of water in the boiler or the system in bars.

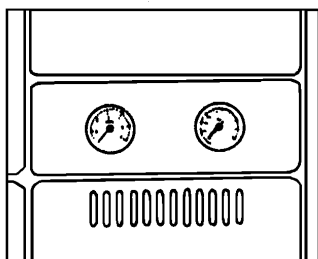

Figure 5

Figure 6

7. PRACTICAL INSTRUCTIONS AND HEATING SYSTEM OPERATION ADVICE

- We recommend you to use a closed circuit, due to corrosion hazard related to open circuits.
- All connections must be well sealed and tightened.
- Before startup, the entire system needs to be tested with water under 2.4 bar pressure.
- It is recommended to discharge the water from the system at least once, to empty the system of dirt.
- For a system to which only the "Alfa term 27" stove is connected, we recommend an expansion vessel of 25 (l) and not more than 18 (l), which should be fitted on the return pipe, as close to the boiler as possible, and no block valves can be fitted between the boiler and expansion vessel.

INSTALLATION DIAGRAM OF STOVE WITH CLOSED CENTRAL HEATING SYSTEM ALFA TERM 27

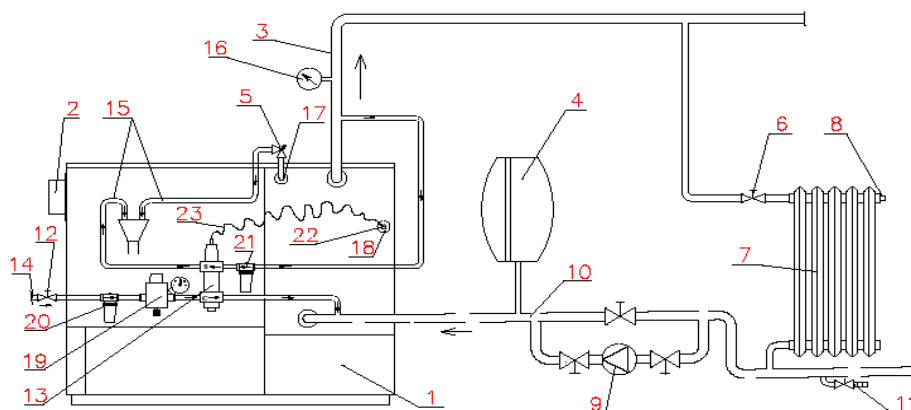

Figure 7

- | | |
|---|--|
| <ol style="list-style-type: none"> 1. Hot water boiler 2. Flue pipe connection 3. Distribution pipe 4. Closed expansion vessel 5. Safety valve 6. Radiator valve 7. Radiator 8. Air vent valve 9. Circulation pump 10. Return pipe 11. Charge and discharge cock 12. Regulation valve | <ol style="list-style-type: none"> 13. Thermal fuse 14. Connection line for water supply system 15. Hot water discharge 16. Manometer 17. Connection for safety valve 18. Connection for thermal valve 19. Pressure regulator 20. Water filter at the input of the boiler 21. Water filter at the output of the boiler 22. Thermal fuse probe 23. Thermal fuse capillary pipe |
|---|--|



Figure 7a

Figure 7b

INSTALLATION OF OPEN CIRCUIT SYSTEM FOR ALFA TERM 27 HEATING STOVE

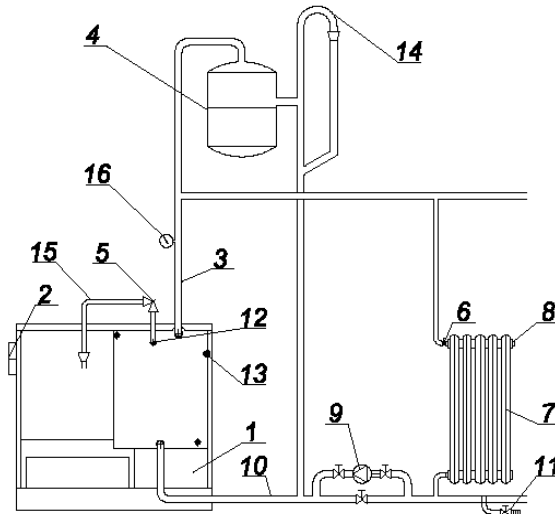

Figure 8

- | | |
|--------------------------|--------------------------------------|
| 1. Hot water boiler | 10. Return pipe |
| 2. Flue pipe connection | 11. Spigot for filling and discharge |
| 3. Distribution pipe | 12. Safety valve connection |
| 4. Open expansion vessel | 13. Thermo valve connection |
| 5. Safety valve | 14. Pressure relief pipe |
| 6. Radiator valve | 15. Hot water outlet |
| 7. Radiator | 16. Pressure gauge |
| 8. Air release valve | |
| 9. Circulation pump | |

-It is preferable to install an R1" multistage pump with a flow rate capacity that always meets current system needs. Install block valves immediately downstream and upstream of the pump to enable removal of pump for repairs, replacement etc. without discharging the water from the system.

-Install the spigot used for filling and discharging the system on the return pump at the lowest point of the system.

-Prior to startup, fill the system with water as follows:

- for open circuits, fill the system using the spigot for filling and discharge, until the water starts to leak from the expansion vessel's overflow pipe,
- for closed circuits, system pressure (operating pressure) should be 0.1 ÷ 0.15 mPa (1 ÷ 1.5 bar).

In both cases, slowly fill the system so that air can escape through air release valves. If the valves are not opened automatically, open them manually until water starts to leak, and then close them.

- Do not discharge water from the heating system even during summer, because it protects the inside of the system from oxidation (corrosion).
- If you will not use the boiler for a longer period during winter and no antifreeze mixture is poured into the system, it is best if you discharge water from the system. While discharging the system, open the radiator valves, air release valves and other system blocking elements.
- You may not light a fire if water in the boiler is frozen or if there is not enough water in the boiler.

8. STARTUP AND LIGHTING THE FIRE

Before you light the fire for the first time, the entire local (central) heating system should be filled with water and well bled, and the stove should be properly connected to the chimney, as described in the foregoing items.

NOTE: The stove may not be used without water. It must be connected to the system, which is connected to consumers (radiators) with the power of no less than 14 KW.

When the system is cold, power regulator (combustion regulator, thermostat) damper located on the ash pan door (Fig. 1, Items 10 and 19) should be open. Pull out the damper open and close knob (Fig. 1, Item 4 and Fig. 15). This opens the damper and enables you to light the fire. Later, when the fire has been burning for a while,

set the damper to an appropriate position, depending on the chimney draw and desired power, and push the knob back. This closes the damper and enables maximum yield of combustion and thereby better heating, cooking and baking. During this process, fire box and ash pan door (Fig. 1, Items 7 and 9) must be closed, if you need controlled burning. Fire lighting damper is opened only while the fire is being lit (10 to 15 minutes). Fire box and ash pan door may be opened and closed manually or using the wrench shown on Figure 6. Fire is lit in the stove the same way as in other solid fuel stoves. Fire is lit with the ash pan door and grate holder open (Fig. 9 and Fig. 10). Grate holder (Fig. 1, Item 13 and Fig. 9) is opened by lifting and pulling. When the fire starts burning, you may load wood or coal, but do not fill the firebox at once and divide the fuel necessary to fill the firebox in two or three portions and load them into the firebox in 10 ÷ 15 minute intervals. A stove loaded in such way can burn for 1 to 6 hours, depending on combustion strength in the stove or on the regulator (thermostat) setting.



Figure 9



Figure 10



Figure 11

The firebox can also be filled from the cooktop (Fig 12). Lift the cooktop lid using a wrench and load the fuel. It is not recommended to burn organic or other waste in the stove (plastic bags, bones, etc.) because this causes formation of tar deposits on the flue duct walls, which can cause a fire. Each time you load the fuel, we recommend that you let the fire burn at maximum strength for at least half an hour, because the first to burn out are all the volatile constituents of the fuel that are usually the main causes to condensate formation in the stove. After plenty of hot fragments have formed, load the portions of coal in two or three steps at 15 minute intervals.



Figure 12

9. USING THE GRATE IN THE UP AND DOWN POSITION

For cooking, baking and heating during transitional season, the grate is in up position (Fig. 11) to ensure that the flame directly reaches the cooktop and saves cooking, baking and heating costs. The stove is delivered with the grate in the down position. To move the grate from down to up position, take the following steps:

- Remove the cooktop from the stove and open the firebox and ash pan door.
- Use your hand, through the ash pan opening and ash pan, to lift the front of the grate and pull it out of its holder.
- Place the grate on the supports (4 pcs) welded inside the boiler firebox, at the front and in the back (2 + 2 pcs) (Fig. 1, Item 23). Place the grate at an angle (slanted) so that the back of the grate can be fitted first, and then lower the front of the grate. Put the cooktop back on the frame.
- The grate is placed in the down position (Fig. 9 and 10) the same way as it is placed in the up position.

Notes:

- Grate in the down position enables better heating of water, heating more radiators and larger living areas, but cooking is more difficult.
- When the grate is in the up position, water is less heated, and less radiators and a smaller living area can be heated, but cooking is much easier.
- Baking is the same in both positions of the grate.

10. AUTOMATIC REGULATION

Stove power is adjusted using the thermostat (power regulator, combustion regulator), which is located in the ash pan door and which automatically sets the regulator damper depending on the regulation knob setting (Fig. 1, Items 10 and 19) and the temperature of water in the boiler. Regulation knob has several positions that are written on the knob as specified in Table 1:

Table 1

Regulator knob position	0	3	4	5	7	9
Temperature of water in the stove (°C)	Regulator closed	30	40	50	70	90

In the power regulation system, air regulator (damper) fully controls combustion air supply if other openings are closed.

11. SECONDARY AND TERTIARY AIR REGULATORS

Secondary air regulator is placed in the firebox door (Fig. 1, Item 8 and Fig. 13). It controls additional lighting of fire and burning unburned flue gases. It is opened and closed manually using the knob on the firebox door.

Leave the secondary air regulator open when the fire in the stove is lit.

Tertiary air regulator (Fig. 1, Item 30) is located behind the tertiary air regulator cover (Fig. 1, Item 27). It controls additional lighting of fire and burning unburned flue gases. It is opened and closed manually using the tertiary air regulator knob (Fig. 1, Item 26).

Leave the tertiary air regulator closed when burning wood and open it when burning coal.

12. COOKING, BAKING AND FRYING

During heating season, the stove is used mainly for heating. For faster baking, cooking and frying, use only dry firewood.

The damper used for starting the fire must be closed and power regulator must be open. After you finish baking, cooking or frying, place the power regulator in desired position.

While baking, increase the temperature of the water in the system to at least 60°C and, if necessary, close some of the radiators during baking and adjust the oven temperature to the food being baked.

NOTE: If necessary, rotate the pan during baking.

13. FUEL

Fuel can be stored in the fuel box (Fig. 14). The fuel box is moved on guides. If you want to take the fuel box out of the stove, you must lift it to remove it from the guides.

Use the fuel specified in Table 2 to ensure the nominal heating capacity of the boiler at chimney draft of 20 Pa. Do not burn coal dust, sawdust or waste that generates large quantities of smoke!



Figure 13



Figure 14

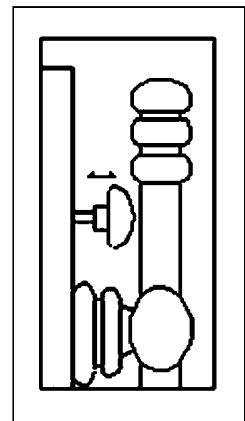

Figure 15

Table 2

Fuel	Calorific value (kJ/kg)
Brown coal	15,000 – 19,000
Dry beech firewood	15,300

NOTE:

To ensure the nominal heating capacity and maximum yield, we recommend you burn dry beech wood cut at the length of L = 33 cm.

14. CLEANING AND MAINTENANCE

Each time before loading the fuel, clean the grate using a small shovel by opening the grate holder or through open firebox door. Remove the ashes from the ash pan at least once a day and remove the larger residues by opening the ash pan door and grate holder. All surfaces of the stove that are in contact with flue gases must be regularly maintained and cleaned using a small shovel. Clean heating areas guarantee cost-effective stove operation. It is recommended to clean the stove once a month or more often, if necessary.

Do not clean enameled surfaces and stove frame using wire brush or wire sponge because it could damage the enamel and safety lining, but use wet cloth, cleaning agents and mild detergent instead. Clean the oven after each use while still hot. After cleaning, leave the oven door open for a few minutes to prevent bad odors the next time you heat the oven.

Clean the cooktop occasionally using fine sandpaper, and in the event of longer breaks, apply acid-free oil on the cooktop (vegetable oil). Remove burnt material from the cooktop with a spatula, knife or treat it with graphite, ashes from the ash pan or oil.

It is prohibited to cool down the stove by making an artificial draft or by using water to cool down the firebox.

15. CONSERVING THE STOVE

At the end of the heating season, clean the stove from ashes and soot. Discharge the water only if any repairs need to be carried out on the installation. If the system is not used during heating season, pour a certain amount of antifreeze liquid into the system or discharge the water to prevent freezing.

16. TROUBLESHOOTING

Table 3

No.	Problem	Possible cause	Repair
1	Water pressure in the system dropping slowly.	Installation is not sealed.	Check whether all welded connections, threaded connections, unions etc. are sealed.
2	Radiators are cold at system's maximum height and a low sound is heard.	Air in the system and small pressure in the system.	Increase system pressure and bleed the air from the system and radiators.
3	Radiators are not heated along their entire length.	Air in the radiators.	Bleed the air from the radiators using release valve.
4	Safety valve is not discharging water from the system and the pressure is below 3 (2.5) bar.	Faulty safety valve.	Replace safety valve.
5	Pressure in the system is over 3 (2.5) bar and safety valve is not discharging water from the system.	Faulty safety valve.	Replace safety valve.
6	Sudden water temperature rise in the system.	Air in the system.	Bleed the air from the radiators.
		Valves toward radiators are shut.	Open all valves in the heating system and enable normal water circulation in the system.
		Circulation pump failure.	Repair or replace the circulation pump to enable heating system operation.
		Power outage.	Open all valves that reduced the heating system and first of all, the by-pass valve. Stop making fire or make less fire and carefully monitor the system so that the water temperature does not exceed 90°C when the power is back on.

7	Sudden water pressure rise in the system due to water temperature increase.	Reduced expansion vessel pressure or vessel is completely empty. Remove the vessel's lid or valve head and bleed some air through the valve. If the membrane is destroyed, water will leak from the valve and if only half-empty, only air will come out.	If water is leaking from the valve, replace expansion vessel. Of only air is coming out from the valve, remove the vessel from the system and apply additional pumping. Vessel pressure should be equal to or higher than the height difference between the highest and lowest point of the system. Example: For a 5 m height difference, the pressure equals $P_{min} \geq 0.5$ bar.
		Air in the system.	Release air from the system.
8	Circulation pump does not activate or it trips the switch	No power at electrical connection. Connectors are loose.	Check and tighten all screws at connection points. Check and, if necessary, replace the switches, fix motor connection or installation connection problems.
		Faulty capacitor.	Replace capacitor.
		Blocked rotor.	Each time you start heating, check whether the rotor turns easily. Hot water deposits can cause the rotor to block. Turn the motor axis left and right using a screw gun until the rotor can move freely.
		The pump is blocked due to deposits.	Dismantle and clean the pump.
9	Thermometer or pressure gauge does not display system temperature or pressure.	Faulty thermometer or pressure gauge.	Replace thermometer or pressure gauge.
10	Noise (murmur) coming from the heating system.	Faulty pump. Large clearance between the rotor axis and nut.	Reduce pump speed. Replace pump nuts or the entire pump.
		Pump speed is too high.	Lower the speed.
		Air in the system.	Bleed the air from the heating system.
		Loose knobs or screws on the stove.	Tighten the knobs and screws.
11	Noise inside the pump.	Too low pressure at suction part of the pump.	Increase system pressure or check expansion vessel.
12	The stove overheats, loud noise (cracking) is heard in the boiler of the stove.	Electricity outage has occurred, the circulation pump does not work and the boiler of the stove overheats. There is a danger of boiler rupture.	To avoid this occurrence, it is best to have backup battery power supply of the circulation pump with an inverter.
			Installation of a thermal exhaust valve (Fig. 7, pos. 13) is required as additional security against stove overheating.
			If you do not have backup supply of the circulation pump or a thermal exhaust valve installed, then you should open the bypass valve connected in parallel with the circulation pump on the pipeline system and remove embers from the stove.

13	Cooling thermal fuse is activated (thermo valve) because water temperature increased over 95°C due to:	Power outage.	This is proper and do not touch anything. When the system is cold, thermal valve will be closed. After that, check the pressure in the installation and fill the system to the required.
		open ash pan door and no controlled combustion	Close the ash pan door and reduce system water temperature using the knob on the ash pan door and thermostat.
		grate in down position and not many radiators are open	Switch the grate to up position or open more radiators. Keep ash pan door closed.
14	Water condensation in the boiler.	Fuel is wet.	Replace fuel.
		Return water temperature is too low.	Install mixer valve or turn a radiator off.
15	Outlet water temperature not right (too low)	Low calorific value of fuel.	Change fuel.
		Oversized heating system (too many radiators)	Turn off some radiators.
		Not enough fuel has been loaded in the firebox.	Increase the quantity of fuel in the firebox.
16	Fire is not burning properly?	Low chimney draft.	Build a new chimney or repair the old one.
		Connecting flue pipes are not sealed. Stove and chimney door are not sealed. Chimney draws "false air".	Seal all joints to prevent occurrence of "false air".
17	Insufficient heat for baking or cooking.	Thermostat set to a low temperature.	Increase water temperature using the thermostat or briefly open the ash pan door.
18	Excessive heat for baking or cooking.	Thermostat set to a high temperature.	Reduce water temperature using the thermostat or burn a smaller fire.
19	Boiler-stove is smoking when used for the first time.	Slight burning and heating of chimney and stove.	It is normal for the stove to smoke a little during first time use and it stops after a while.
20	Boiler-stove is smoking during regular use.	Chimney, flue pipes and stove not cleaned.	Clean the inside of the chimney, flue pipes and stove.
		Wet fuel or you are using fuel that is generating a lot of smoke.	Change fuel. Use dry fuel or smokeless fuel.
		Firebox is overloaded.	Gradually fill the firebox, in several steps.
		Poor quality chimney.	Repair your chimney or build a new one.
21	Grate is stuck during shaking.	A nail, debris or other material is stuck on the grate.	Clean the grate from unwanted objects.

17.0 GUARANTEE CONDITIONS

17.1. TIME OF GUARANTEED SERVICING

This implies the period during which we guarantee the service, accessories and space parts, starting from the day of purchase of the device.

The time of guaranteed servicing is in accordance with the valid legal regulations.

In case of change of the model and the design of the device, the term for change of parts that have modified design is within the legal term.

After this term we provide the modified parts in the new designs.

17.2. CONDITIONS OF THE GUARANTEE

The guarantee of the product is valid within the legally defined term.

The guarantee is not valid for the glass, the glass-ceramic panel and the physical damages that have occurred after purchase.

THE MANUFACTURER RETAINS ALL THE RIGHTS TO MAKE CHANGES.

The device will properly function within the guaranteed term only if it is used in accordance with these guidelines for connection and application.

The guarantee cases to apply if it is determined that:

- the connection or the repair of the product was performed by an unauthorized person, that is, if unoriginal parts have been embedded,
- if the device has not been properly used in accordance with these guidelines,
- if some mechanical damaging of the device occurred during usage,
- if the repairs of defects were performed by an unauthorized person,
- if the device has been used for commercial purposes,
- if the damage has occurred during transportation after the device was sold,
- if the defects occurred due to improper mounting, improper maintenance or mechanical damaging by the buyer,
- if the defect occurred after too strong or insufficient power, as well due to force major.

We can repair the defects of Your device also outside the guaranteed period, with original spare parts for which we also provide a guarantee under the same conditions.

This guarantee does not exclude or affect the rights of the customer in regard to the conformity of the goods pursuant to the legal regulations. If the delivered product does not conform to the agreement, the customer has the right to ask the seller to repair that lack of conformity without any reimbursement, by repair or change of the product in accordance with the valid legal regulation

TABLE OF CONTENTS:

0. TECHNICAL DATA.....	1
1. PURPOSE	3
2. APPEARANCE AND STRUCTURE OF STOVE WITH BOILER FOR HEATING (Fig. 1)	3
3. SAFETY AND RELIABILITY OF STOVE OPERATION	3
4. INSTALLING THE STOVE	3
5. CONNECTING TO CHIMNEY.....	5
6.1 FLOW PIPE AND RETURN PIPE (Fig. 4, Items 1 and 2 and Fig. 7 and 8, Items 3 and 10)	7
<u>6.2 THERMAL VALVE WITH BUILT-IN THERMAL PROTECTION AND ADDITIONAL ELEMENTS FOR CONNECTION</u>	
6.2.1 THERMAL VALVE WITH BUILT-IN THERMAL PROTECTION (Fig. 7, Item 13 and Fig. 7a)	
6.2.2 SLOPE PRESSURE REGULATOR 1/2" WITH MANOMETER (Fig. 7, Item 19 and Fig. 7b)	
6.2.3 WATER FILTER OF THE BOILER INTAKE (Fig. 7, Item 20)	
6.2.4 WATER FILTER OF THE BOILER OUTLET (Fig. 7, Item 21)	
6.3 SAFETY VALVE (Fig. 7 and 8, Item 5 and Fig. 4, Item 6)	8
6.4 THERMOMETER AND PRESSURE GAUGE (Fig. 1, Items 16 and 17 and Fig. 5)	8
7. PRACTICAL INSTRUCTIONS AND HEATING SYSTEM OPERATION ADVICE	9
8. STARTUP AND LIGHTING THE FIRE.....	10
9. USING THE GRATE IN THE UP AND DOWN POSITION	11
12. COOKING, BAKING AND FRYING.....	12
13. FUEL.....	12
15. CONSERVING THE STOVE.....	13
16. TROUBLESHOOTING	13
17. WARRANTY	Error! Bookmark not defined.

Outline dimensions of ALFA TERM 27 stove

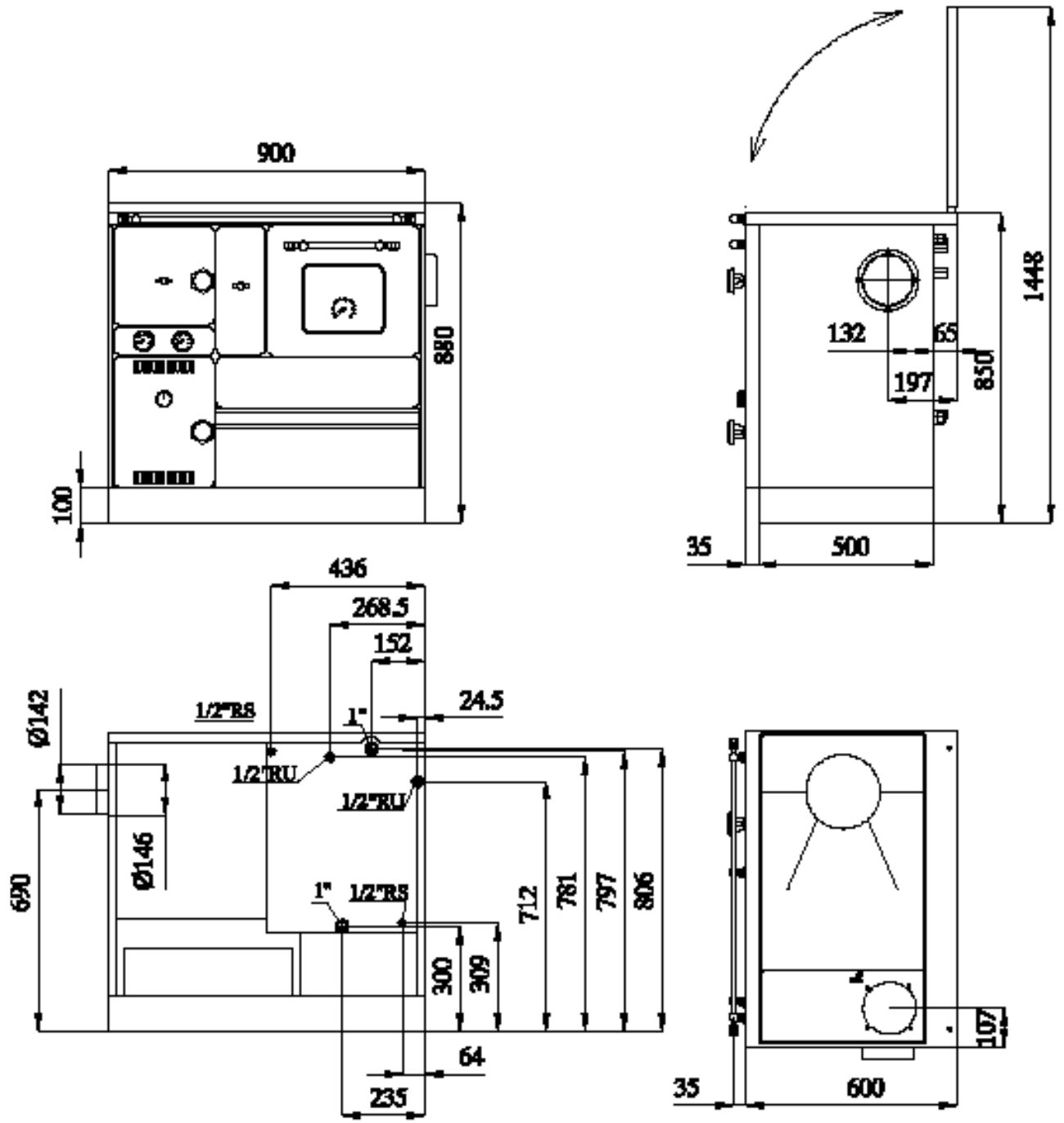

Figure 16